

1 2 3 4 5 6 7 8 9 10 11 12

A

B

C

D

E

F

G

H

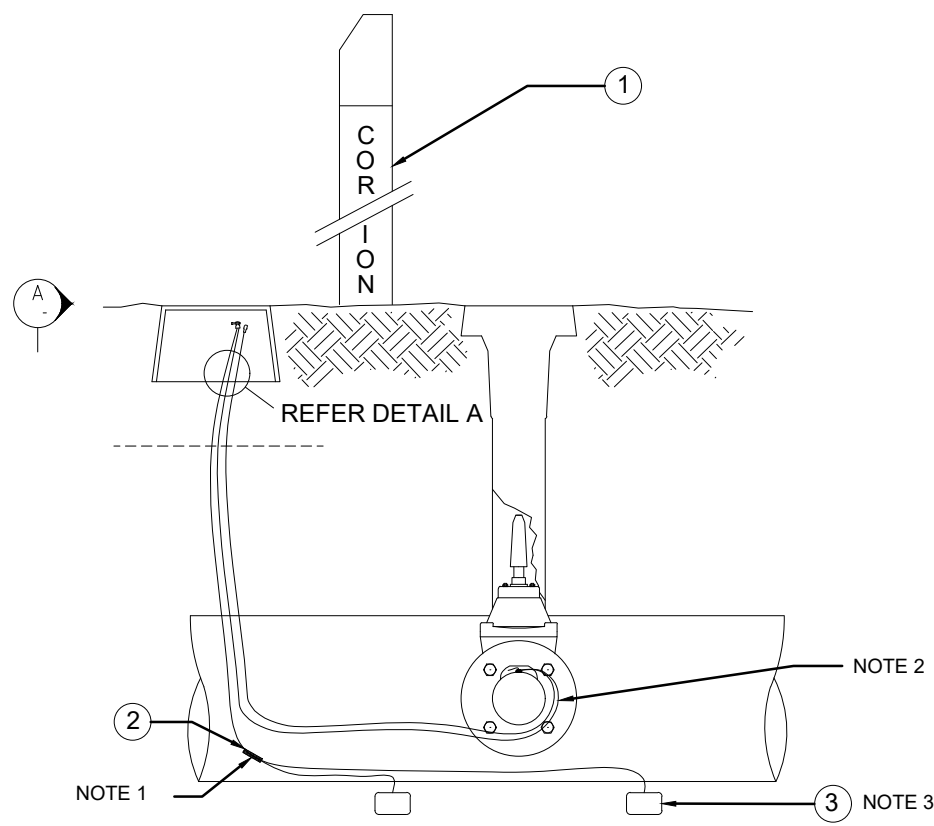

**SIDE ELEVATION**

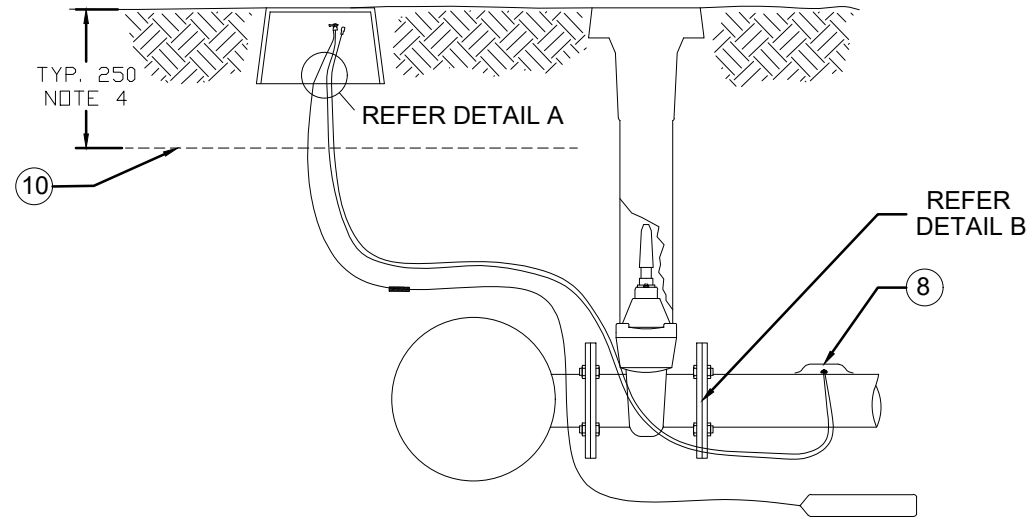

**SECTION A**

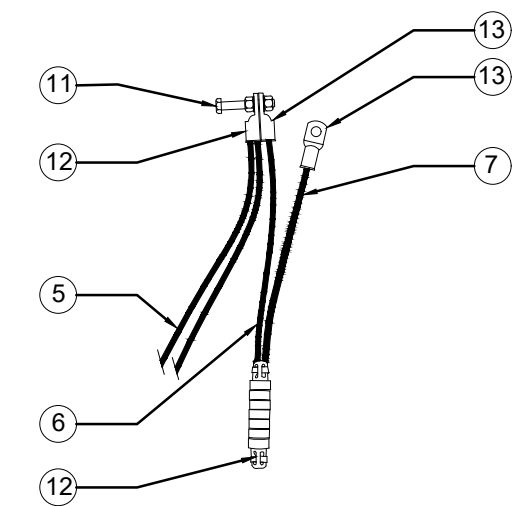

**DETAIL A**

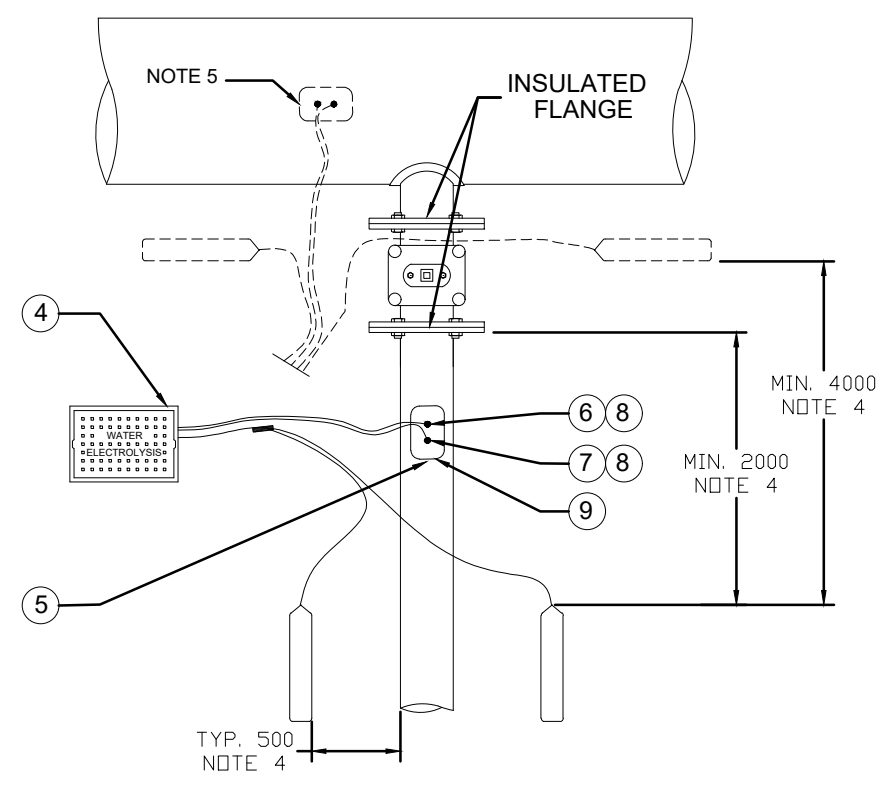

**PLAN**

CABLE ENDS CAD WELDED TO 25 x 50 x 6 MILD STEEL TAB, WELDED TO PIPE FLANGE & SEALED

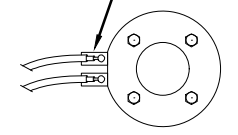

**DETAIL B**  
ALTERNATE CABLE TO PIPE CONNECTION

ITEM No	DESCRIPTION	DETAIL
1	TEST POINT MARKER POST	TO WATER AUTHORITY REQUIREMENTS
2	COPPER CRIMP LINK	TO SUIT 16 Sqmm CABLE, SEALED WITH HEAT SHRINK SLEEVE (ACTIVATED GLUE)
3	SACRIFICIAL ANODE	TYPE AND NUMBER DEPENDANT ON DESIGN REQUIREMENTS
4	ELECTROLYSIS TEST POINT BOX (TREGEAR BOX)	C/W CAST IRON LID EMBOSSED 'WATER ELECTROLYSIS. REFER REFERENCES
5	ANODE LEADS	6 Sqmm COPPER RED PVC
6	CABLE POTENTIAL LEAD	16 Sqmm SDI RED WITH WHITE PVC SHEATH
7	CABLE CURRENT LEAD	16 Sqmm SDI RED WITH WHITE PVC SHEATH
8	CABLE PIPE CONNECTION	THERMIT (CADWELD 15 GRAM WELDING CHARGE), LEADS AT min 30MM APART
9	COATING REINSTATEMENT	BUTYL MASTIC FILLER & REPAIR PATCH TO MANUFACTURERS GUIDELINES.
10	ELECTRICAL UNDERGROUND MARKER TAPE	ORANGE - 'DANGER BURIED ELECTRIC CABLE BELOW'
11	ANODE CABLE LUG CONNECTION	M6, 25mm STAINLESS STEEL BOLT, 2 NUTS & 2 WASHERS ADAPT ASSEMBLY TO SUIT No OF ANODES / BOND CONNECTIONS
12	CABLE IDENTIFICATION	TO WATER AUTHORITY REQUIREMENTS
13	CABLE LUG	TO SUIT 16 Sqmm CONDUCTOR, 6mm HOLE

**NOTES**

- JOIN ANODE LEADS BENEATH SURFACE IF INDIVIDUAL CABLE LENGTHS ARE INSUFFICIENT OTHERWISE JOIN WITHIN TEST BOX.
- SAG CABLE AROUND AND BELOW PIPE TO REDUCE TENSION ON CABLE PIPE CONNECTION. TAPE CABLE TO PIPE WALL USING BUTYL TAPE (DENSO 60) OR EQUIVALENT.
- PLACE ANODES AT BOTTOM OF TRENCH AGAINST WALLS OF EXCAVATION OR ADJACENT TO TOP OF PIPE IF EXCAVATION DEPTHS ARE RESTRICTIVE. PROVIDE A MINIMUM CLEARANCE OF:
  - 1 METRE SEPARATION BETWEEN OTHER METALLIC SERVICES.
  - 2 METRE SEPARATION FROM PIPE FITTING & SIGNIFICANTLY DEGRADED OR DAMAGED PIPE COATINGS.
 WHERE ANODES ARE INSTALLED ON BOTH SIDES OF AN INSULATING JOINT, PLACE ANODES 2 METRES FROM OF THE INSULATING JOINT (TOTAL SEPARATION OF 4 METRES BETWEEN ANODES).
- ALTERNATE DIMENSION TO BE APPROVED BY WATER AUTHORITY.
- WAT-1410 OR WAT-1411 TEST POINT DEPENDANT ON DESIGN REQUIREMENT.
- ALL DIMENSIONS SHOWN IN MILLIMETRES.

**REFERENCES**

- DRAWING WAT-1411 STEEL MAIN CATHODIC PROTECTION SYSTEMS FULL CONSTRUCTION TEST POINT CONNECTION
- CORR-09 ELECTROLYSIS TEST POINT REQUIREMENTS; INSTALLATION, MAINTENANCE AND ABANDONMENT
- DRAWING SCP.02.03 ELECTROLYSIS TEST POINT SURROUND
- DRAWING ES-10-5 (MW DRAWING REFERENCE) LID FOR ELECTROLYSIS TEST POINT SURROUND
- DRAWING WCP.150 (WITS DRAWING REFERENCE) LID FOR ELECTROLYSIS TEST POINT SURROUND

REV	DESCRIPTION	DATE	APP'D
1.3	LOGO REVISED 2021		ML
1.2	REDRAWN FROM REV 1.1 ISSUED 2004		JM

DESIGNED WIG	DRAWN J.MYRLAINEN
DESIGN CHECK WATER INDUSTRY GROUP	DRAFT CHECK AUG 2018
APPROVED WIG	DATE MAY-18



MELBOURNE WATER / MELBOURNE RETAIL WATER AGENCIES  
**STEEL MAIN CATHODIC PROTECTION SYSTEMS**  
 PART CONSTRUCTION ELECTROLYSIS TEST POINT CONNECTION  
 TYPICAL FOR ISOLATED PIPE SECTIONS - NO POTENTIAL LOG REQUIREMENT

DO NOT SCALE		
SCALE:	NTS	
DRAWING NUMBER		
WAT-1410-M		1.3
SHEET	OF	REV
11	12	